

4 - 20mA Input / Output, Isolated Signal Conditioner

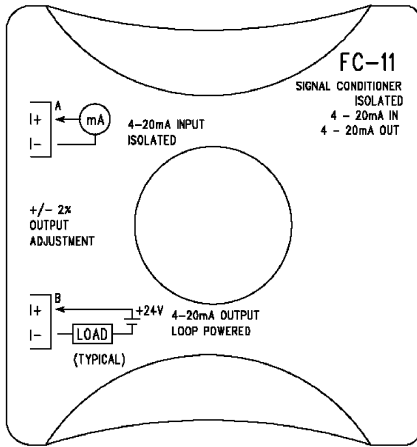
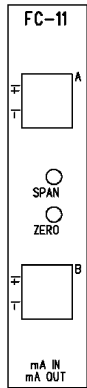

Description

The FC-11 is a DIN rail mount, 4 - 20mA input / output signal conditioner with 1500VDC isolation between input and output.

The FC-11 is factory-calibrated, but also has OFFSET (zero) and SPAN (full scale) adjustments of the output signal. The OFFSET (zero) has an adjustment range of 0 to 25% of full scale input, the SPAN (full scale) has an adjustment of 80% to 102%

Application

The FC-11 isolated input/output signal conditioner is useful in eliminating ground loops, sinking / sourcing issues when interfacing to PLC analog input modules. The FC-11 design feature solves many types of configuration problems. For example, the signal conditioner can solve sinking input transmitter to sinking input analog modules. It also allows signal translation from current input to voltage output.

This feature would be useful when you have limited type and number of channels in your system design, i.e. 8 channels of 0 - 10VDC, 7 which are used and one input transmitter that is 4 - 20mA.

Specifications	
Input Range	4-20mA
Extended input range ₁	3.5mA to 20.6mA, ± 1%
Input Burden Voltage ₂	6.8VDC
Maximum Input Current	34mA@9.7VDC
Output Burden Voltage ₃	8.5VDC minimum
Output Range	4-20mA
Extended output range ₁	3.5mA to 20.6mA, ± 1%
Maximum Load Impedance	650Ω@24VDC, 1000Ω@29VDC
Maximum Output Current	23mA@29VDC
Sample Duration Time	18mS maximum
Filter Characteristic	-3dB@ 200Hz -6dB / octave
Linearity Error	0.1% FSO maximum
Stability	0.1% FSO maximum
Accuracy vs. Temperature	± 0.0065% / °C (65ppm/°C)
Maximum Inaccuracy of output (includes offset, span, linearity)	25°C 0.05% FSO maximum 0 - 60°C 0.3% FSO maximum
Isolation	1500VDC input - output

NOTE: All data 0 - 60° C except where specified.

- ¹ When adjusting output SPAN and OFFSET potentiometers.
- ² Voltage required to power internal circuitry.
- ³ Formula - ((output load) x 20mA) + 8.5V
i.e. 13.5VDC @ 250Ω
- ⁴ Internal Analog convertor resolution is 12-bit.

Input / Output Operation

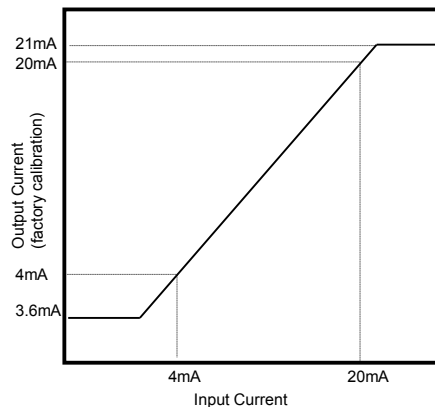

Adjustments

The FC-11 has built-in calibration, but also has OFFSET (zero) and SPAN (full scale) adjustment of the output signal. If your application requires, different span or offset (i.e. 3.6mA offset and 19.6mA span) you can adjust accordingly.

It is suggested if your application does not need modified OFFSET or SPAN - DO NOT ADJUST potentiometers since this loses the factory calibration.

Application adjustments

Calibrating the minimum output signal level -

1. Connect minimum input signal level.
2. Adjust the OFFSET potentiometer for the minimum output.
3. Connect the maximum input signal level.
4. Adjust the SPAN potentiometer for the maximum output.

To return to factory calibration -

This calibration sequence requires an accurate digital multi meter, 6 or more digits, a handheld DMM that only has 4½ digits is **NOT** accurate enough.

1. Apply 4.0 mA, adjust the OFFSET potentiometer to read this current (i.e. 4.00000mA).
2. Apply 20.0mA, adjust the SPAN potentiometer to read this current (i.e. 20.0000mA).
3. The signal conditioner is returned to factory calibration.

Operating Temperature	0 to 60°C (32 to 140°F)
Storage Temperature	-20 to 70°C (-4 to 158°F)
Relative Humidity	5 to 90% (non-condensing)
Environmental air	No corrosive gases permitted
Vibration	MIL STD 810C 514.2
Shock	MIL STD 810C 516.2
Noise Immunity	NEMA ICS3-304

Typical Connection -

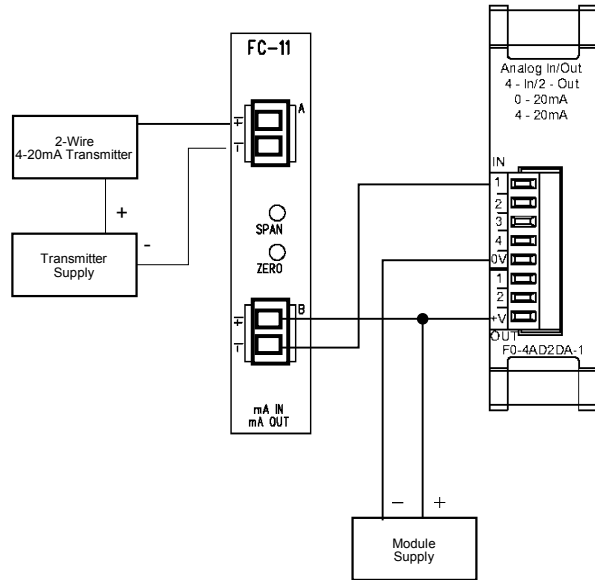

4 -20mA Input Isolated to 4 - 20mA Output (example)

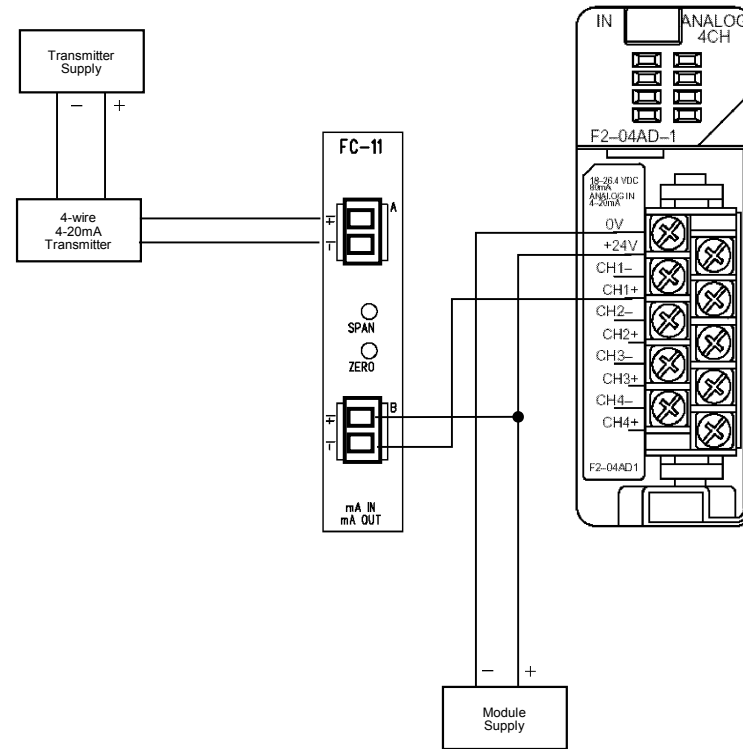

4-Wire Transmitter, 4-20 mA Input to 4-20 mA Sinking Input (example)

THIS EQUIPMENT IS SUITABLE FOR USE IN CLASS I, DIVISION 2, GROUPS A, B, C AND D OR NON-HAZARDOUS LOCATIONS ONLY.
 WARNING – EXPLOSION HAZARD - SUBSTITUTION OF COMPONENTS MAY IMPAIR SUITABILITY FOR CLASS I, DIVISION 2 / ZONE 2.
 WARNING – EXPLOSION HAZARD - DO NOT DISCONNECT EQUIPMENT UNLESS POWER HAS BEEN SWITCHED OFF OR THE AREA IS KNOWN TO BE NON-HAZARDOUS.