

Sinking and Sourcing Concepts

When choosing the type of input or output module for your system (or DL05/DL06/DL105 I/O type), it is very important to have a solid understanding of sinking and sourcing concepts. Use of these terms occurs frequently in discussion of input or output circuits. It is the goal of this section to make these concepts easy to understand, so you can make the right choice the first time when selecting the type of I/O points for your application. This section provides short definitions, followed by general example circuits.

First you will notice that the diagrams on this page are associated with only DC circuits and not AC, because of the reference to (+) and (-) polarities. *Therefore, sinking and sourcing terminology applies only to DC input and output circuits.* Input and output points that are sinking or sourcing can conduct current in one direction only. This means it is possible to connect the external supply and field device to the I/O point, with current trying to flow in the wrong direction, and the circuit will not operate. However, the supply and field device can be connected every time based on an understanding of sourcing and sinking.

The figure below depicts a *sinking* input. To properly connect the external supply, it must be connected so the input provides a path to supply common(-). So, start at the PLC input terminal, follow through the input sensing circuit, exit at the common terminal, and connect the supply (-) to the common terminal. By adding the switch between the supply (+) and the input, the circuit is completed. Current flows in the direction of the arrow when the switch is closed.

By applying the circuit principles to the four possible combinations of input/output sinking/sourcing types, there are four circuits, as shown above. The common terminal is the terminal that serves as the common return path for all I/O points in the bank.

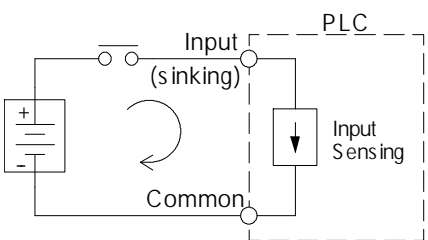

Sinking = provides a path to supply **common (-)**

Sourcing = provides a path to supply **source (+)**

Sinking Input
(IEC: positive logic)

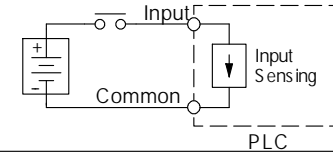

Sinking Output
(IEC: negative logic)

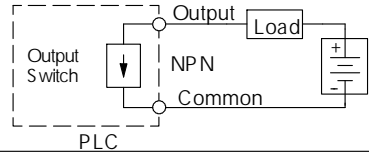

Sourcing Input
(IEC: negative logic)

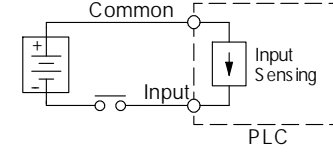

Sourcing Output
(IEC: positive logic)

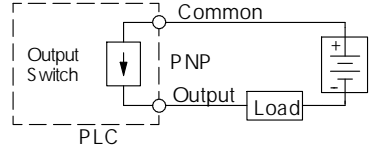

Sink/source I/O circuits combine sinking and sourcing capabilities. This means that the I/O circuitry in the PLC will allow current to flow in either direction, as shown at the right. The common terminal connects to one polarity, and the I/O point connects to the other polarity (through the field device). This provides flexibility in making connections to your field power supply. Please note:

- Wire all I/O points with a shared common as either sinking or sourcing.
- Do not use an AC power supply on a DC sink/source I/O point.

Sink/Source Input
(IEC: pos./neg. logic)

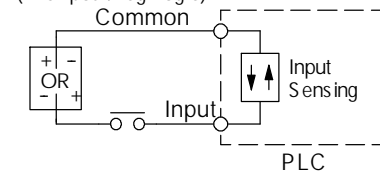

Sink/Source Output
(IEC: pos./neg. logic)

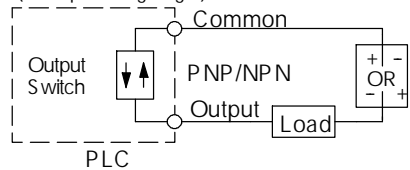

Field device examples - 3 wire connections

NPN (Sinking)
Field Device Example

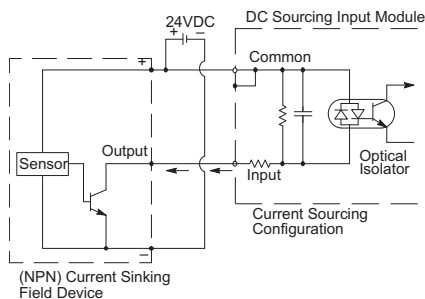

PNP (Sourcing)
Field Device Example

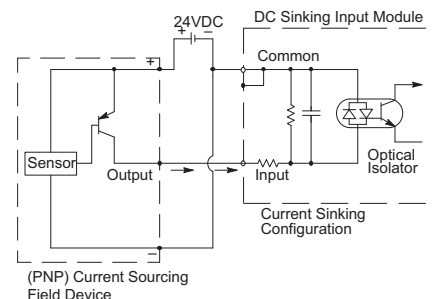

Sinking and Sourcing Concepts

Common terminals and how to use them

In order for a PLC I/O circuit to operate, current must enter at one terminal and exit at another. This means at least two terminals are associated with every I/O point. In the figure at the right, the input or output terminal is the main path for the current. One additional terminal must provide the return path to the power supply. Together, the main path and the return path create a loop, or a complete circuit for current to flow.

If there was unlimited space and budget for I/O terminals, then every I/O point could have two dedicated terminals. However, providing this level of flexibility is not practical or even necessary for most applications. So, most input or output points on PLCs are in groups that share the return path (called *commons*). The figure at the right shows a group (or bank) of four input points that share a common return path. In this way, the four inputs require only five terminals instead of eight.

NOTE: Assuming all input circuits have a similar resistance, the current at the common terminal is four times greater than the current at any one of the inputs. This effect is especially important to note for output circuits, where the current through a common terminal can reach several amperes. You will need to decide whether to fuse each output point individually, or to put a fuse in the common terminal path.

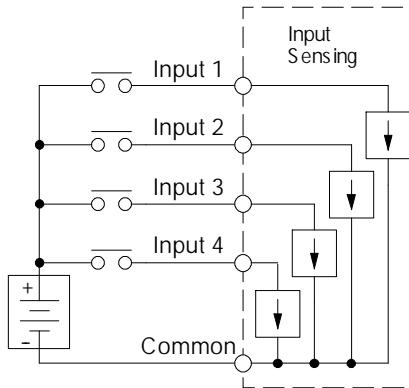
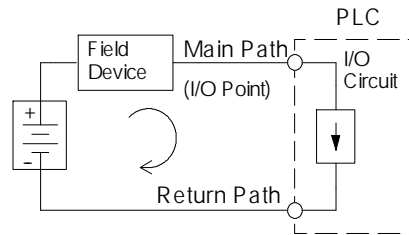

grouped into banks that share a common return path. The best indication of I/O common grouping is on the wiring label. Sample DL05, DL06 and DL105 wiring labels and their meanings are shown below.

Wiring labels and how to interpret them

DL205, DL305, DL405 - Most DL205, DL305 and DL405 input and output modules group their I/O points into banks that share a common return path. The best indication of I/O common grouping is on the wiring label, such as the one shown at the right. The miniature schematic shows two circuit banks with eight input points in each. The common terminals are labeled "CA" and "CB," respectively.

In the wiring label example, the positive terminal of a DC supply connects to the common terminals. Some of the symbols you will see on wiring labels and their meanings are shown at the right.

DL05/DL06/DL105 — Most DL05, DL06 and DL105 input and output circuits are

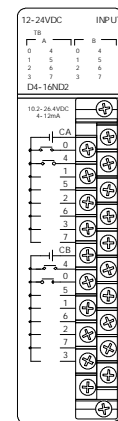
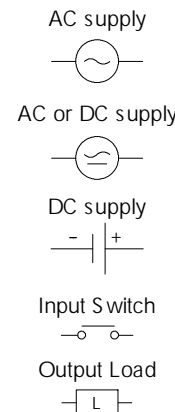

DL405 input module shown

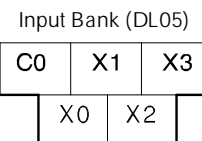

Two banks of four inputs and two banks of three outputs (DL05)

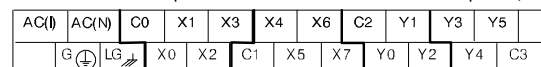

I/O Common Grouping Bar (DL105)



Two banks of four inputs and one bank of two (DL105)

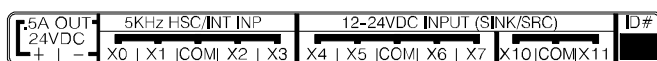

ISO 9001/UL/CUL/EU/RoHS

Throughout the world, there is a wide variety of regulatory codes, agency approvals, and other types of certification that may be required in order to install an automation system. These requirements vary and depend on your exact location and situation. For example, there may be national codes, state and local government codes, and even wide-ranging requirements such as the European Union (EU) Directives. The following are some of these codes and requirements, and explanations of how they may affect you as a PLC and industrial controls user.

ISO 9001

Some companies require their suppliers to use products that are built by companies that adhere to a documented set of quality-related procedures. ISO 9001 is one of the standards in the ISO 9000 family of standards for quality management systems. Koyo Electronics Industries Company, Ltd., the manufacturer of most of our PLC products, is an ISO 9001 certified company, as are many of our other Federation members. Some copies of the ISO certificates are available on our Web site.

Underwriters Laboratories (UL/CUL)

Underwriters Laboratories is one of the world's premier safety testing and certification sources. Many applications require UL approval for insurance and/or other compliance purposes. There are several areas of interest, but the most applicable are: UL508, the standard for Industrial Control Equipment; and UL1604, the standard covering Hazardous Locations. For more information on the Underwriters Laboratories, check their Web site at www.ul.com. There are several tables in this section that show which of our products have a UL listing. (They also indicate the cUL approval, which is required in many applications in Canada.) Please check our Web site for the most current information.

European Union (EU) Directives

This area of certification and approval is absolutely vital to anyone who wants to do business in Europe. One of the key tasks that faced the EU member countries and the European Economic Area (EEA) was the requirement to bring several similar, yet distinct, standards together

into one common standard for all members. The primary purpose of a single standard was to make it easier to sell and transport goods between the various countries and to maintain a safe working and living environment. The Directives that resulted from this "harmonization" of standards are now legal requirements for doing business in Europe. Products that meet these Directives are required to have a CE mark to signify compliance. A few key questions are always asked when the subject of CE is discussed.

Which Directives apply to me? Several Directives apply to our products, and Directives may be amended or added, as required.

- **Electromagnetic Compatibility Directive (EMC)** – Provides a means to ensure that products placed on the market do not generate electromagnetic disturbances that would affect other apparatus, including radio and/or telecommunications equipment.
- **Machinery Safety Directive** – Covers the safety aspects of the equipment, installation, etc. There are several areas involved, including testing standards covering both electrical noise immunity and noise generation.
- **Low Voltage Directive** – Is also safety related and covers electrical equipment that has voltage ranges of 50-1,000 VAC and/or 75-1,500 VDC.
- **Battery Directive** – Covers the production, recycling, and disposal of batteries.

Who is responsible for ensuring compliance with these Directives? Ultimately, we are all responsible for our various pieces of the puzzle. Manufacturers must test their products and document any test results and/or installation procedures necessary to comply with the Directives. As a machine builder, you are responsible for installing the products in a manner that will ensure compliance is maintained. You are also responsible for testing any combinations of products that may (or may not) comply with the Directives when used together. The end user of the products must comply with any Directives that may cover maintenance, disposal, etc. of equipment or various components. Although we strive to provide the best assistance available, it is impossible for us to test all possible configurations of the products we carry with respect to any specific Directive. Because of this, it is ultimately your responsibility to ensure that your machinery (as a whole) complies with these Directives and to keep up with applicable Directives and/or practices

that are required for compliance.

Which DirectLOGIC products carry the CE label? As of March, 2002, selected DL05, DL06, DL205, DL305, DL405 and Terminator I/O PLC systems manufactured by Koyo Electronics Industries, Host Engineering or FACTS Engineering, when properly installed and used, conform to the Electromagnetic Compatibility (EMC), Low Voltage Directive, and Machinery Directive requirements of the standards on the next page.

EC 61000-3-2 Power Factor Correction

The IEC 61000-3-2 standard is intended to reduce the amount of disturbance a device feeds back into its power source. AutomationDirect power supplies all carry the CE mark. Normally, 61000-3-2 is met or does not apply. Only our PS24-150D and PS24-300D could potentially be used in a manner not compliant with the 61000-3-2 standard.

RoHS

The Restriction of Hazardous Substances (RoHS) Directive 2002/95/EC [1] was adopted in February 2003 by the EU. The RoHS directive, which took effect July 1, 2006, restricts the use of six hazardous materials in the manufacture of various types of electrical and electronic equipment. RoHS is linked with the Waste Electrical and Electronic Equipment Directive (WEEE) 2002/96/EC which sets collection, recycling and recovery targets for electrical goods and is part of a legislative initiative to solve the problem of large amounts of toxic e-waste.

Each EU member state will adopt its own enforcement and implementation policies using the directive as a guide. Therefore, there could be as many different versions of the directive as there are states in the EU.

RoHS is often referred to as the lead-free directive, however, it restricts the use of the following six substances:

- Lead
- Mercury
- Cadmium
- Hexavalent chromium (chromium VI or Cr 6+)
- Polybrominated biphenyls (PBB)
- Polybrominated diphenyl ether (PBDE)

For a listing of all products and their compliance status see:

<http://support.automationdirect.com/compliance.html#rohs>